

Class 300 Stainless Steel/Carbon Steel Ball Valves

Full bore, Split body, Side entry design

- Conform to NACE MR0175 for hardness of body, body cap, stem and ball.

Features

- Antistatic device
- Blowout-proof stem
- Fire test certification★(API 607, ISO 10497)
- Stem head conform to CAPI ADDS 2.02 dimensions
- High performance **HYPATITE® PTFE** ball seats
- Actuator mounting pad to ISO 5211

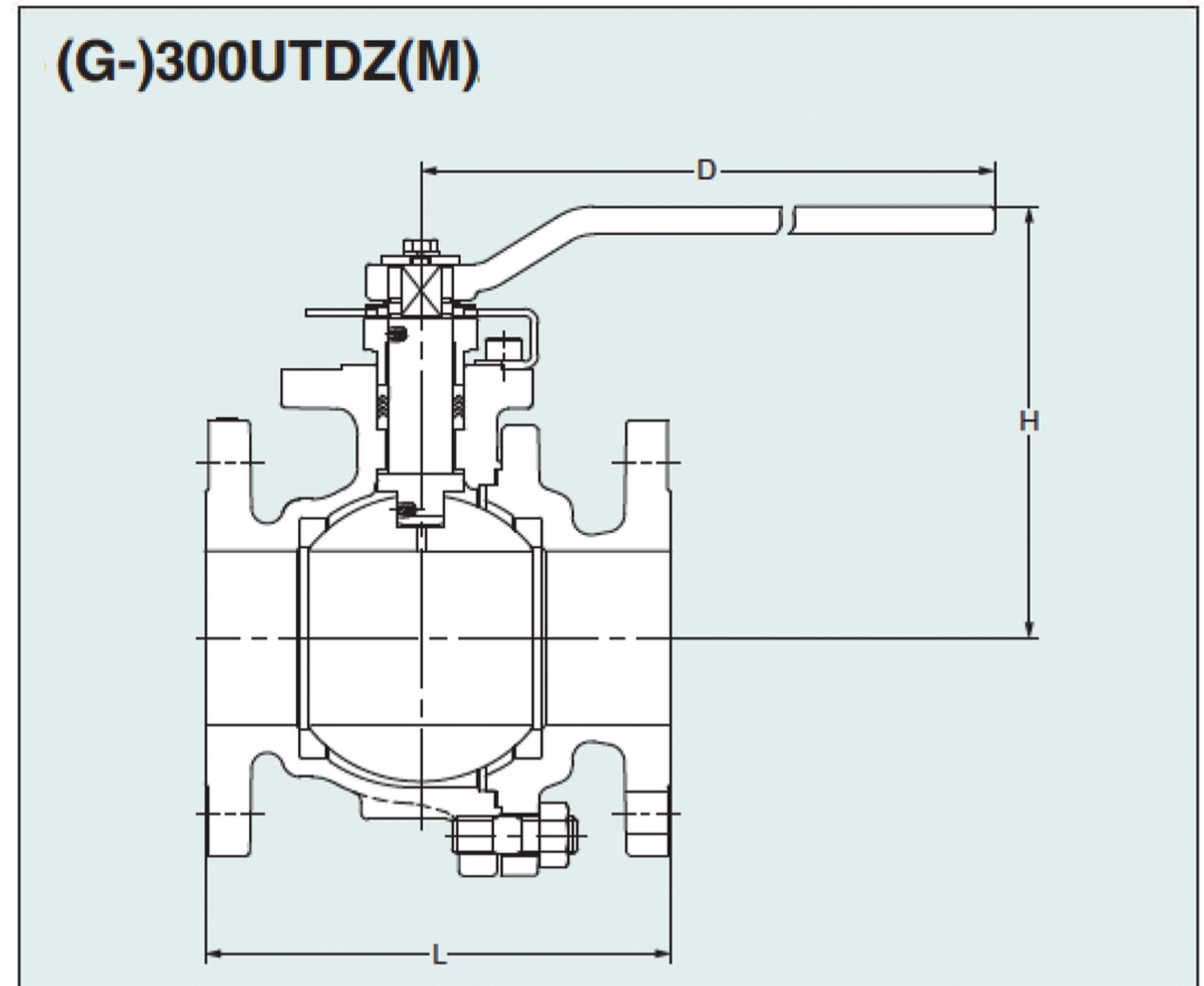

Dimensions of 300UTDZ(M), 300SCTDZ

Unit: mm

Nominal Size	NPS	1/2	3/4	1	1 1/4*	1 1/2	2	2 1/2	3	4	5	6	8
	DN	15	20	25	32*	40	50	65	80	100	125	105	200
Ball bore		14	19	24	32	38	50	64	76	100	123	151	202
L		140	152	165	178	190	216	241	283	305	381	403	502
H		108	111	124	128	134	143	179	189	251	267	315	406
D		130	130	160	160	230	230	400	400	750	750	1000	1500

Valve operator

NPS 1/2 to 8: Lever operation
NPS 6 to 8: Optional gear operation

Option

- ★ Flexible graphite packing and gasket (See Pages 11 and 43)
- Ball and stem to 316ss available in carbon steel valves upon request

Gear Operation

Unit: mm

Nominal Pressure	Class 150	Class 300	Gear Operator										
			H		D		C		A				
			150	300	150	300	150	300	150	300			
Nominal size (NPS)	4	4		258		310		165		65.5			
	5		274		254		165		65.5				
	6	6	322	335	310	360	165	210	66.5	88.5			
	8	8	412	412	360	360	210	210	88.5	88.5			
	10		448	—	500	—	363	—	93.5	—			

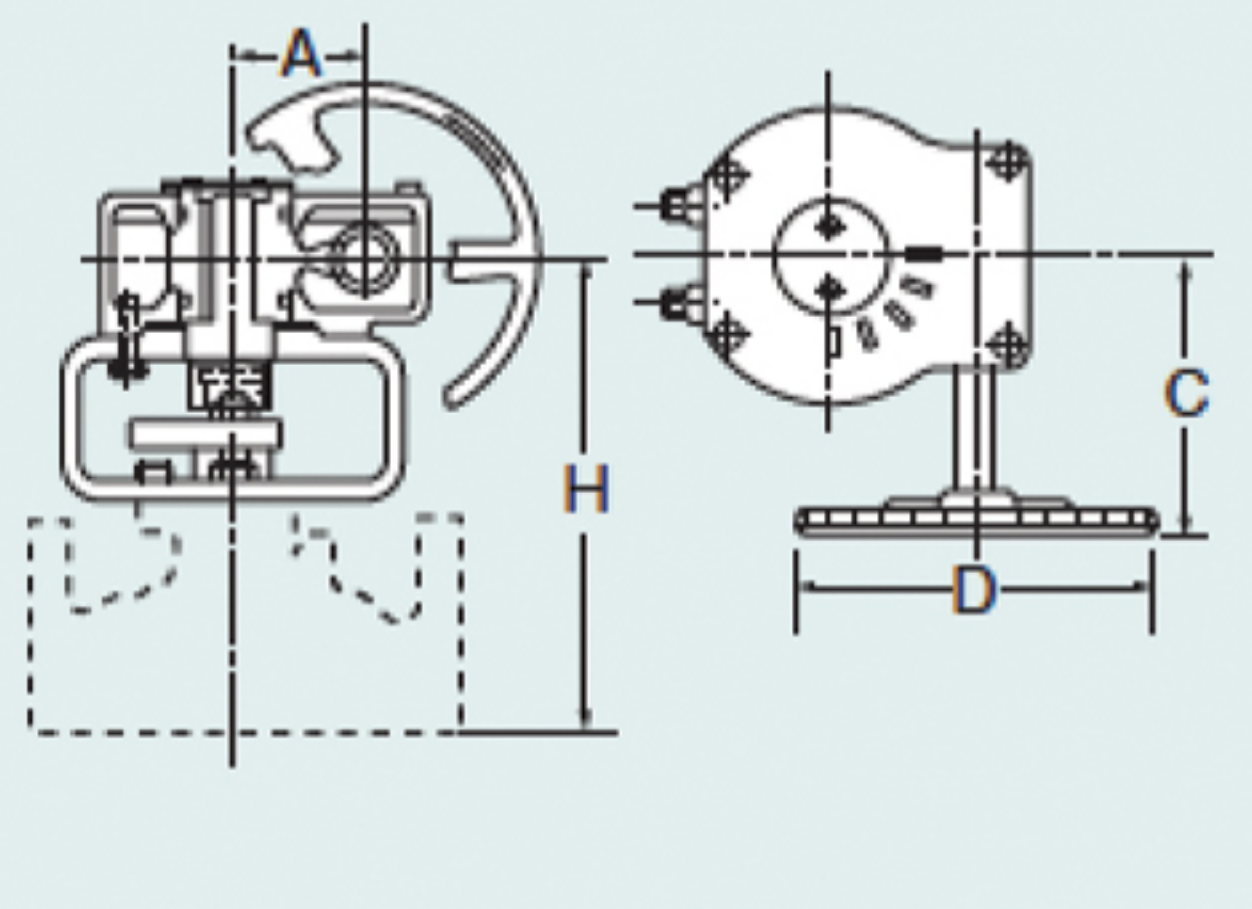

Worm gear operators may be mounted on KITZ ball valves at your option for the smoothest valve operation. Electric or pneumatic actuators are also optionally available. Contact KITZ distributors for appropriate choice and sizing of valve actuators.

Refer to "Product Range" on Page 1.